



**Wednesday, January 25, 2012**

**12:00 Noon**

*(Lunch Provided for Board Members)*

**Kelly Board Room**

**32-505 Harry Oliver Trail**

**Thousand Palms, CA 92276**

**NOTE:** IN COMPLIANCE WITH THE AMERICANS WITH DISABILITIES ACT, IF YOU NEED SPECIAL ASSISTANCE TO PARTICIPATE IN THIS MEETING, PLEASE CONTACT SUNLINE AT (760) 343-3456. NOTIFICATION 48 HOURS PRIOR TO THE MEETING WILL ENABLE SUNLINE TO MAKE REASONABLE ACCOMMODATION TO ENSURE ACCESSIBILITY TO THIS MEETING.

**THE CHAIR REQUESTS THAT ALL CELLULAR PHONES AND PAGERS BE TURNED OFF OR SET ON SILENT MODE FOR THE DURATION OF THE BOARD MEETING.**

**AGENDA TOPICS**

**RECOMMENDATION**

1. **Call to Order**  
Chairman Eduardo Garcia
2. **Flag Salute**
3. **Roll Call**
4. **Presentations**
5. **Finalization of Agenda**
6. **Correspondence**  
None.

**7. Public Comments****Receive Comments**

(NOTE: Those wishing to address the Board should complete a Public Comment Card and will be called upon to speak.)

**NON AGENDA ITEMS**

Anyone wishing to address the Board on items not on the agenda may do so at this time. Each presentation is limited to 3 minutes.

**AGENDA ITEMS**

Anyone wishing to address specific items on the agenda should notify the Chair at this time so those comments can be made at the appropriate time. Each presentation is limited to 3 minutes.

**8. Board Member Comments****Receive Comments**

Any Board Member who wishes to speak may do so at this time.

----- **ACTION** -----

**9. Consent Calendar****Approve**

All items on the Consent Calendar will be approved by one motion, and there will be no discussion of individual items unless a Boardmember requests a specific item be pulled from the calendar for separate discussion. The public may comment on any item.

- a) Minutes of the December 7, 2011 Board of Directors Meeting (Pages 1-6)
- b) Checks over \$1,000 for November, December 2011 (Pages 7-10)
- c) Credit card statement for November, December 2011 (Pages 11-16)
- d) Monthly Budget Report for November, 2011 (Pages 17-18)
- e) Contract Report – November, 2011 (Page 19).
- f) Ridership Report for November, December 2011 (Pages 20-23)
- g) SunDial Operational Notes for November, December 2011 (Pages 24-25)

-----

**10. General Counsel (C. Mikel Oglesby)****Approve**

Request to the Board to accept resignation of SunLine Transit Agency/SunLine Services Group Legal Counsel, approve appointment of interim Legal Counsel. (Page 26)

**11. General Manager's Report (C. Mikel Oglesby)**

**12. Next Meeting Date**

February 22, 2012

12 o'clock Noon – Kelly Board Room

32-505 Harry Oliver Trail

Thousand Palms, CA 92276

**13. Adjourn**

**MINUTES**  
**SunLine Transit Agency**  
**Board of Directors Meeting**  
**December 7, 2011**

A regular meeting of the SunLine Transit Agency Board of Directors was held at 12:00pm on Wednesday, December 7, 2011 in the Kelly Board Room at SunLine Transit Agency, 32-505 Harry Oliver Trail, Thousand Palms, CA 92276.

**1. Call to Order**

The meeting was called to order at 12:00 p.m. by Chairman Eduardo Garcia.

**2. Flag Salute**

Chairman Garcia led all in a salute to our flag.

**3. Roll Call**

Completed.

**Members Present**

Eduardo Garcia, Chairman, Mayor, City of Coachella  
Robert Spiegel, Vice Chairman, Mayor Pro Tem, City of Palm Desert  
Yvonne Parks, Mayor, City of Desert Hot Springs  
Steve Pougnet, Mayor, City of Palm Springs  
G. Dana Hobart, Mayor, City of Rancho Mirage  
Bud England, Councilmember, City of Cathedral City  
Bill Powers, Mayor Pro Tem, City of Indian Wells  
Glenn Miller, Mayor Pro Tem, City of Indio  
John J. Benoit, Supervisor, County of Riverside

**Members Absent**

Don Adolph, Mayor, City of La Quinta

**Guests:**

Joseph Pradetto- Supervisor John Benoit's Office  
Joe Perez- Ralphs Grocery Store  
Peter Kurzon- American Cab  
Bruce Klopstock- American Cab  
Kevin Folwer- American Cab  
Greg Kennedy- American Cab  
Lars Thane- American Cab  
Elliot Pike- American Cab  
Harry Incs – American Cab  
Scott Russo- Legal Counsel for American Cab  
K.D. Labana- Airport Taxi  
Mabu Hossain- Airport Taxi  
Gadi Srulovitz- Yellow Cab

Bill Meyer- Yellow Cab  
Michal Brock- Yellow Cab  
Carlos Cruz- Yellow Cab  
Christopher Flicker- KESQ  
Marc Blaine- KESQ  
Keith Matheny- Reporter, Desert Sun  
James Braico- VIP Transportation  
Terry Berger- Express Transportation  
Peter Angone- Public  
Kimberly Webb- Public

**Staff:**

C. Mikel Oglesby, General Manager  
Maria Aarvig, Legal Counsel  
Carolyn Rude, Special Asst. to the General Manager/Clerk of the Board  
Tommy Edwards, Director of Maintenance  
Tommy Green, Director of Safety & Security  
Polo Del Toro, Director of Operations  
Naomi Nightingale, Director of Administration & Human Resources/EEO/Taxi Administrator  
Joe Forgiarini, Director of Planning  
Rudy LeFlore, Procurement Consultant  
Cis LeRoy, Interim Director of Finance  
Jack Stevens, Human Resources Manager  
Mike Morrow, Maintenance Manager  
Michael Jones, Manager Taxicab Administration  
Manny Garcia, Operations Senior Supervisor  
David Manriquez, Safety Specialist  
Dave Robin, Assistant Taxicab Supervisor II  
Diann Chumney, Marketing Specialist II  
Mannie Thomas, Manager of Operations  
Francine DePalo, Administrative Assistant  
Vanessa Mora, Administrative Assistant  
Amy Heilman, Coin Counter

**4. Presentations**

Naomi Nightingale, Director of Administration & Human Resources/EEO, presented to Mr. Joe Perez, a representative from Ralphs, Palm Springs, a plaque in appreciation of their participation in the Agency's annual "Fill-the-Bus" charity food drive. Ms. Nightingale stated that the Ralphs in Bermuda Dunes and two Stater Bros. stores participated as well. The contributions went to the Coachella Valley Rescue Mission, the Galilee Center in Coachella and to the Soup Kitchen in Desert Hot Springs. Over ten and a half tons of food was delivered to the three agencies. A round of applause was given by the Board.

**5. Finalization of Agenda**

Legal Counsel, Maria Aarvig requested that agenda item 18a, Closed Session – Conference on Labor Negotiation – be pulled. Vice Chairman Spiegel moved to finalize agenda with requested change. Councilmember England seconded the motion and agenda was approved by a unanimous vote.

**6. Correspondence**

None.

**7. Public Comments****NON AGENDA ITEMS:**

None.

**AGENDA ITEMS:**

None.

**8. Board Member Comments**

Mayor Pro Tem Miller thanked SunLine staff, as well as Chairman Garcia, for attending the grand opening of the new bus route in Indio. He stated that a tour of the new Line was provided which will take residents back and forth from north Indio to south Indio or from the heart of the City to shopping centers. He stated that the new line is very well received from residents.

**9. Finance Department Update**

Interim Finance Director, Cis LeRoy addressed the Board with an update on the three annual audits – the FTA's annual National Transit Database Report, the audit by RCTC's auditors and the State Controller's Annual Report. She stated that they are in progress and everything is going well. Ms. LeRoy stated that they are almost complete with very few comments.

**10. Transit Monthly Budget Report Update**

Interim Finance Director, Cis LeRoy addressed the Board stating that a new finance report format that will be presented to the Board monthly, now shows local revenue, state revenue and federal operating revenue. She stated that at a previous Finance Committee meeting a Board member had questions about Measure A revenue. A new report format was created. The new report has a new line item – grant revenue, and an additional page that shows all revenue.

**11. Consent Calendar**

Vice Chairman Spiegel moved for approval of the consent calendar. The motion was seconded by Mayor Pro Tem Miller and approved by a unanimous vote.

**12. Construction Management Contract Approval**

Mikel Oglesby addressed the Board requesting that authorization be given to the General Manager to negotiate and execute a contract for construction management services subject to review and approval as to form by SunLine Legal Counsel. He stated that the Administrative building project will use FTA funding and requires an

engineering firm on property. SunLine does not have an engineering dept. or engineering staff to provide technical construction oversight. The cost is included in the capital project budget and will be funded from a combination of Prop. 1B and FTA funds. Mayor Pro Tem Powers moved for approval. The motion was seconded by Vice Chairman Spiegel and approved by a unanimous vote.

**13. Purchase of Fuel Cells**

Mikel Oglesby addressed the Board stating that he has great news – two days after the unveiling of the American Fuel Cell Bus, the FTA announced the award of grant funding to SunLine for two additional American Fuel Cell buses. He stated that the Agency will make history once again by adding two additional American Fuel Cell buses to the Agency fleet. Oglesby requested that the Board grant authorization to the General Manager to negotiate and execute a contract with Ballard Power Systems for two fuel cells. Oglesby stated that the total amount of the contract is approximately \$1.2 million. Mayor Pro Tem Powers moved for approval. The motion was seconded by Vice Chairman Spiegel and approved by a unanimous vote.

**14. Approval to Open New Bank Account**

Interim Finance Director, Cis LeRoy addressed the Board stating that previously the Board approved establishing a bank account for an Employee Relief Fund, which is funded entirely by employee donations. She stated that staff recommends to open a new bank account at Robobank where SunLine has no other account to keep the program completely separate. Supervisor Benoit moved for approval. The motion was seconded by Councilmember England and approved by a unanimous vote.

**15. Approval of New ACCESS Advisory Committee Member**

Director of Operations, Apolonio Del Toro addressed the Board requesting approval of a new member on the ACCESS Advisory Committee, who was approved by the current Committee members. Councilmember England moved for approval. The motion was seconded by Mayor Pro Tem Miller and approved by a unanimous vote.

**16. General Manager's Report**

Mikel Oglesby reminded the Board of the Agency's holiday gala, which will be held Friday, December 9<sup>th</sup> from 6:00pm – 11:00pm at the Westin in Rancho Mirage. He stated that employees appreciate Board member's attendance.

Oglesby provided a powerpoint presentation to the Board highlighting the accomplishments this year by the Agency. Oglesby stated that the Agency hosted the Annual "State of Public Transit" Luncheon with keynote speaker Bill Millar and Dr. John Wu as guest speaker. He stated that in the upcoming year, staff is attempting to bring a surprise speaker as we will be celebrating the Agency's 35<sup>th</sup> anniversary. Oglesby stated that we provided transportation for the Valley's "Farewell to Betty Ford" which required many vehicles; our sister agencies came on board to assist in providing the community an opportunity to pay their respect. Oglesby stated that we are doing some great things in relation to SunFuels. We have unique facilities where we sell CNG and hydrogen to the public. Oglesby

stated that our technology is actually beyond Weights and Measures when it comes to figuring out how much to charge per gallon equivalent. They have actually worked with our staff to come up with a solution not only for SunLine, but for all hydrogen fueling stations in the industry and the United States. SunLine received a temporary permit to sell hydrogen per gallon equivalent, which is huge. Oglesby stated that those who sell hydrogen per gallon equivalent will use SunLine's model. Another first! Oglesby stated this is big in the industry and when we get the permanent permit, he will let the Board know.

Oglesby shared additional Agency accomplishments:

- o Dedication of the new Maintenance Bay Expansion – used federal funding and promoted jobs.
- o Launch of the Taxi Voucher Program – shows there is unification; staff will look to find another grant and funds to further support the program.
- o Annual “Fill-the-Bus” food drive – collected 10.5 tons of donations for three local charity organizations.
- o Partnered with the City of Indio implementing the Line 80 changes just in time for the holidays.
- o The unveiling of the seventh generation hydrogen bus, the American Fuel Cell Bus.
- o Announcement of funding by the FTA for two more American Fuel Cell Buses.
- o Heading into the 35<sup>th</sup> Anniversary.

#### 17. **Next Meeting Date**

Chairman Garcia announced that the next regular meeting of the Board of Directors will be held on January 25, 2012 at 12 noon – Kelly Board Room, 32-505 Harry Oliver Trail, Thousand Palms, CA 92276.

At 12:20pm Chairman Garcia announced that the Board recess the SunLine Transit Board Meeting and open SSG Board meeting.

At 1:16pm Chairman Garcia announced to reconvene SunLine Transit Agency meeting and move into closed session.

#### 18. **Closed Session**

Item 18a pulled from agenda

- a) Closed Session - Conference on Labor Negotiations pursuant to Government Code Section 54957.6: C. Mikel Oglesby and Tom Hock (via phone conference). Employee Organization: Amalgamated Transit Union, Local 1277 representing drivers, mechanics and other trades.
- b) Closed session to review the employee performance evaluation of Legal Counsel, pursuant to Government Code Section 54957 of the California Government Code.
- c) Closed session to review the employee performance evaluation of the General Manager, pursuant to Government Code Section 54957 of the California Government Code.

At 1:46 pm, Chairman Garcia announced that the Board will resume open session of SunLine Transit Agency. Legal Counsel reported no reportable action on 18b. Ms. Aarvig stated that on agenda item 18C, the Board approves unanimously a performance incentive, per the contract of the General Manager calculated on the basis of 6.68%.

**19. Adjourn**

Chairman Garcia adjourned the meeting at 1:47p.m.

Respectfully Submitted

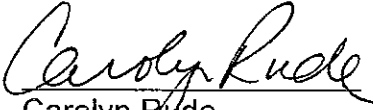
  
Carolyn Rude  
Clerk of the Board

Approved By:

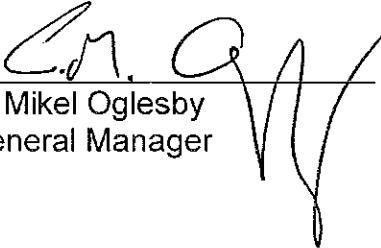
  
C. Mikel Oglesby  
General Manager

Date: 1/17/12

**SunLine Transit Agency**  
**Checks \$1,000 and Over**  
**For the month of November 2011**

NOTE: 1). Bold check payments represent "pass through" payments that were, or will be reimbursed to SunLine under the provisions of specific grants or contracts. 2). Underlined check payments represent "shared" payments with SunLine and specific vendors/employees.

<b>Vendor Name</b>	<b>Description</b>	<b>Check #</b>	<b>Check</b>	<b>Amount</b>
<u>HEALTH NET</u>	Group Health Ins Prem	652433	11/8/2011	\$193,824.67
<u>HEALTH NET</u>	Group Health Ins Prem	652489	11/10/2011	\$193,660.09
SO CAL GAS CO.	Utilities	652619	11/18/2011	\$90,435.73
<u>UNION BANK</u>	Pension Deposits	652519	11/10/2011	\$78,759.43
PERMA	GnrI Liab / Wker Comp	652611	11/18/2011	\$74,486.65
<b>IBI GROUP</b>	<b>Engineer Services</b>	<b>652586</b>	<b>11/18/2011</b>	<b>\$43,168.51</b>
GOODYEAR TIRE & RUBBER COMPANY,	Bus Tire Lease	652573	11/18/2011	\$20,866.02
IMPERIAL IRRIGATION DIST	Utilities	652587	11/18/2011	\$20,518.08
<b>TRAPEZE GROUP</b>	<b>WIP-Trapeze Software Upgrade</b>	<b>652663</b>	<b>11/22/2011</b>	<b>\$14,569.00</b>
<u><b>LEFLORE GROUP LLC, THE</b></u>	<u><b>Projects Management</b></u>	<u><b>652494</b></u>	<u><b>11/10/2011</b></u>	<u><b>\$12,777.50</b></u>
COACHELLA VALLEY ECONOMIC	Membership & Subscriptions	652476	11/10/2011	\$10,000.00
<b>DESERT ALARM, INC.</b>	<b>WIP-Maint Bldg Rehab-ARRA</b>	<b>652415</b>	<b>11/8/2011</b>	<b>\$9,625.00</b>
SOUTHWEST NETWORKS, INC.	Network Consultants	652511	11/10/2011	\$9,600.00
GFI GENFARE	Farebox	652488	11/10/2011	\$8,296.75
CREASON & AARVIG, LLP	Legal Services	652479	11/10/2011	\$7,574.00
<b>COLONIAL LIFE &amp; ACCIDENT</b>	<b>Supplemental Insurance</b>	<b>652410</b>	<b>11/8/2011</b>	<b>\$6,437.82</b>
<u>METLIFE SBC</u>	<u>Dental Insurance</u>	<u>652440</u>	<u>11/8/2011</u>	<u>\$5,983.93</u>
<b>MIKE COX ELECTRIC, INC. THE</b>	<b>WIP-Seismic Warning System</b>	<b>652595</b>	<b>11/18/2011</b>	<b>\$5,810.40</b>
IMW INDUSTRIES, INC.	CNG Parts	652588	11/18/2011	\$4,800.76
TRANSIT PRODUCTS & SERVICES	Repair Parts	652628	11/18/2011	\$4,703.08
MOORE MAINTENANCE & JANITORIAL	Janitorial Servs	652596	11/18/2011	\$4,633.00
ZACHARY WAYNE JOHNSON	Directors Workshop	652639	11/18/2011	\$4,476.79
<u><b>SOUTHWEST NETWORKS, INC.</b></u>	<u><b>Network Consultants</b></u>	<u><b>652458</b></u>	<u><b>11/8/2011</b></u>	<u><b>\$4,425.00</b></u>
<u>AMALGAMATED TRANSIT UNION</u>	<u>Union Dues</u>	<u>652469</u>	<u>11/10/2011</u>	<u>\$4,306.12</u>
G & K SERVICES	Uniform service	652569	11/18/2011	\$4,125.96
<u><b>SOUTHWEST NETWORKS, INC.</b></u>	<u><b>Network Consultants</b></u>	<u><b>652659</b></u>	<u><b>11/22/2011</b></u>	<u><b>\$4,031.25</b></u>
RESORT MARKETING	Public Relations Mgmt	652615	11/18/2011	\$3,625.00
CUMMINS CAL PACIFIC, LLC	Bus Repair Parts	652551	11/18/2011	\$3,516.22
TELEPACIFIC COMMUNICATIONS	Telephone Service	652660	11/22/2011	\$3,367.62
TELEPACIFIC COMMUNICATIONS	Telephone Service	652461	11/8/2011	\$3,259.86
CARQUEST OF THE DESERT	Repair Parts	652542	11/18/2011	\$3,214.04
IMPERIAL IRRIGATION DIST	Utilities	652491	11/10/2011	\$3,108.36
CIS LeROY	Interim Finance Dir/Consultant	652545	11/18/2011	\$3,009.92
<b>ERIC COREY FREED</b>	<b>Engineer Services</b>	<b>652556</b>	<b>11/18/2011</b>	<b>\$3,000.00</b>
<b>KAMINSKY PRODUCTIONS, INC</b>	<b>Marketing Consultants</b>	<b>652591</b>	<b>11/18/2011</b>	<b>\$2,909.38</b>
FIESTA FORD, INC.	Repair Parts/Support	652565	11/18/2011	\$2,667.11
VERIZON WIRELESS	Wireless Cell Service	652522	11/10/2011	\$2,624.23
ALLIEDBARTON SECURITY SERVICES	Security Services	652403	11/8/2011	\$2,491.44
KENNY STRICKLAND, INC.	Lubricants & Oils	652650	11/22/2011	\$2,489.20
BURRTEC WASTE & RECYCLING	Facility Trash Removal	652534	11/18/2011	\$2,345.03
NEW FLYER	Bus Parts	652604	11/18/2011	\$2,182.31

**SunLine Transit Agency**  
**Checks \$1,000 and Over**  
**For the month of November 2011**

NOTE: 1). Bold check payments represent "pass through" payments that were, or will be reimbursed to SunLine under the provisions of specific grants or contracts. 2). Underlined check payments represent "shared" payments with SunLine and specific vendors/employees.

<b>Vendor Name</b>	<b>Description</b>	<b>Check #</b>	<b>Check</b>	<b>Amount</b>
<u>CALIFORNIA STATE DISBURSEMENT</u>	Employee Garnishment	<u>652472</u>	11/10/2011	<u>\$2,171.60</u>
<u>EYE MED</u>	Employee Benefits	<u>652484</u>	11/10/2011	<u>\$2,158.40</u>
NEW FLYER	Bus Parts	652444	11/8/2011	\$2,132.29
FLEET-NET CORPORATION	Software & Licenses	652485	11/10/2011	\$2,040.00
TOTALFUNDS BY HASLER	Postage Meter Supplies	652626	11/18/2011	\$2,000.00
<b><u>OFFICE DEPOT</u></b>	<b><u>F/A-Office Furn/Equip</u></b>	<b><u>652607</u></b>	<b><u>11/18/2011</u></b>	<b><u>\$1,997.47</u></b>
HOME DEPOT CRD SRVS	Facility Maintenance	652585	11/18/2011	\$1,942.71
TRANSIT PRODUCTS & SERVICES	Repair Parts	652463	11/8/2011	\$1,931.53
<b>KAMAN INDUSTRIAL TECHNOLOGIES</b>	<b>F/A-SunFuels Equip</b>	<b>652437</b>	<b>11/8/2011</b>	<b>\$1,776.64</b>
GFI GENFARE	Fare box	652647	11/22/2011	\$1,711.18
CAL-TEST, INC.	D&A Onsite Testing	652473	11/10/2011	\$1,707.45
ALLIEDBARTON SECURITY SERVICES	Security Services	652527	11/18/2011	\$1,660.96
FACTORY MOTOR PARTS COMPANY	Repair Parts	652560	11/18/2011	\$1,612.48
ROMAINE ELECTRIC CORP.	Repair Parts	652616	11/18/2011	\$1,566.39
FIESTA FORD, INC.	Repair Parts/Support	652423	11/8/2011	\$1,554.70
NAOMI NIGHTINGALE	APTA Conference	652502	11/10/2011	\$1,552.15
VERIZON	Communications	652521	11/10/2011	\$1,529.01
SIGN A RAMA	Signage	652510	11/10/2011	\$1,412.62
VALLEY OFFICE EQUIPMENT, INC.	Fax/Copier Supplies	652464	11/8/2011	\$1,405.95
CREATIVE BUS SALES, INC.	Bus Repair Parts	652412	11/8/2011	\$1,387.69
PARKHOUSE TIRES INC	Revenue/Non-Rev Tires	652609	11/18/2011	\$1,374.98
EMC	Medical-Exams and Testing	652555	11/18/2011	\$1,350.00
NEW FLYER	Bus Parts	652654	11/22/2011	\$1,314.75
<u>SHERIFF'S COURT SERVICES - EAST</u>	Employee Garnishment	<u>652509</u>	11/10/2011	<u>\$1,305.44</u>
CREATIVE BUS SALES, INC.	Bus Repair Parts	652549	11/18/2011	\$1,274.35
UTC POWER CORPORATION	Fuel Cell Bus Parts	652633	11/18/2011	\$1,241.28
OFFICE DEPOT	Office Supplies	652655	11/22/2011	\$1,229.86
KENNY STRICKLAND, INC.	Lubricants & Oils	652592	11/18/2011	\$1,160.61
GOODYEAR TIRE & RUBBER COMPANY,	Bus Tire Lease	652648	11/22/2011	\$1,156.35
SAFETY-KLEEN CORPORATION	Solvent Tank Service	652617	11/18/2011	\$1,118.07
ACCONTEMPS	Temporary Help	652400	11/8/2011	\$1,116.00
ACCONTEMPS	Temporary Help	652468	11/10/2011	\$1,116.00
VALLEY OFFICE EQUIPMENT, INC.	Fax/Copier Supplies	652665	11/22/2011	\$1,084.93
PROMOTIONAL, INC.	Employee of Qtr. Recognition	652505	11/10/2011	\$1,047.26
CARQUEST AUTO PARTS - INDIO	Repair Parts	652538	11/18/2011	\$1,016.34
OSBORNE RINCON, CPA'S	CPA-Consultant-ERF	652447	11/8/2011	\$1,000.00

<b>Total of Checks Over \$1,000</b>	<b>\$939,862.70</b>
<b>Total of Checks Under \$1,000</b>	<b>\$51,814.22</b>
<b>Total of All Checks for the Month</b>	<b>\$991,676.92</b>
<b>Total Amount of Checks Prior Years Same Month</b>	<b>\$868,171.22</b>

**SunLine Transit Agency**  
**Checks \$1,000 and Over**  
**For the month of December 2011**

NOTE: 1). Bold check payments represent "pass through" payments that were, or will be reimbursed to SunLine under the provisions of specific grants or contracts. 2). Underlined check payments represent "shared" payments with SunLine and specific vendors/employees.

<b>Vendor Name</b>	<b>Description</b>	<b>Check #</b>	<b>Check</b>	<b>Amount</b>
<u>HEALTH NET</u>	Group Health Ins Prem	652777	12/9/2011	\$208,661.07
<u>UNION BANK</u>	Pension Deposits	652997	12/22/2011	\$82,419.73
<u>UNION BANK</u>	Pension Deposits	652693	12/1/2011	\$79,278.36
<u>UNION BANK</u>	Pension Deposits	652837	12/9/2011	\$78,293.18
GOODYEAR TIRE & RUBBER COMPANY,	Bus Tire Lease	652774	12/9/2011	\$21,147.45
IMPERIAL IRRIGATION DIST	Utilities	652961	12/22/2011	\$19,387.22
<b>TRAPEZE GROUP</b>	<b>WIP-Trapeze Software Upgrade</b>	<b>652692</b>	<b>12/1/2011</b>	<b>\$13,808.00</b>
HST LESSEE MISSION HILLS LP	Holiday Gala Employee Event	652959	12/22/2011	\$13,433.20
<b>C.V.A.G.</b>	<b>Federal JARC Funding</b>	<b>652938</b>	<b>12/22/2011</b>	<b>\$13,278.39</b>
<b><u>LEFLORE GROUP LLC, THE</u></b>	<b><u>Projects Management</u></b>	<b><u>652785</u></b>	<b><u>12/9/2011</u></b>	<b><u>\$11,349.22</u></b>
<u>HARTFORD LIFE</u>	Employee Benefits	652677	12/1/2011	\$10,403.66
TRAPEZE GROUP	Consultant for Planning Dept	652994	12/22/2011	\$10,317.10
<b>BLUWAYS USA, INC.</b>	<b>WIP-THOR/AT BUS</b>	<b>652670</b>	<b>12/1/2011</b>	<b>\$10,000.00</b>
SOUTHWEST NETWORKS, INC.	Network Consultants	652987	12/22/2011	\$7,931.25
SOUTHWEST NETWORKS, INC.	Network Consultants	652821	12/9/2011	\$7,856.25
<b>COLONIAL LIFE &amp; ACCIDENT</b>	<b>Supplemental Insurance</b>	<b>652673</b>	<b>12/1/2011</b>	<b>\$6,437.82</b>
<b>ERIC COREY FREED</b>	<b>Engineer Services</b>	<b>652952</b>	<b>12/22/2011</b>	<b>\$6,000.00</b>
<u>METLIFE SBC</u>	Dental Insurance	652681	12/1/2011	\$5,946.09
PROFESSIONAL TRANSIT	Legal-Labor Counsel	652685	12/1/2011	\$5,815.51
CIS LEROY	Interim Finance Dir./Consultant	652737	12/9/2011	\$5,306.24
G & K SERVICES	Uniform service	652767	12/9/2011	\$5,081.92
MOORE MAINTENANCE & JANITORIAL	Janitorial Servs	652790	12/9/2011	\$4,633.00
KENNY STRICKLAND, INC.	Lubricants & Oils	652966	12/22/2011	\$4,605.65
<u>AMALGAMATED TRANSIT UNION</u>	Union Dues	652710	12/9/2011	\$4,361.30
<u>AMALGAMATED TRANSIT UNION</u>	Union Dues	652930	12/22/2011	\$4,361.30
<u>AMALGAMATED TRANSIT UNION</u>	Union Dues	652668	12/1/2011	\$4,339.96
<b>TRAPEZE GROUP</b>	<b>Upgrade Software</b>	<b>652834</b>	<b>12/9/2011</b>	<b>\$4,176.90</b>
CARQUEST OF THE DESERT	Repair Parts	652731	12/9/2011	\$4,110.86
RESORT MARKETING	Public Relations Mgmt	652811	12/9/2011	\$4,000.00
ACCONTEMPS	Temporary Help	652926	12/22/2011	\$3,794.40
TRAPEZE GROUP	Subscription Software Mtce	652995	12/22/2011	\$3,737.00
COMTO	Membership	652945	12/22/2011	\$3,500.00
TELEPACIFIC COMMUNICATIONS	Telephone Service	652990	12/22/2011	\$3,282.19
DESERT AIR CONDITIONING, INC.	A/C Repairs	652747	12/9/2011	\$3,032.00
NAME WITHHELD	Insurance Losses	652745	12/9/2011	\$2,775.37
NEW FLYER	Bus Parts	652972	12/22/2011	\$2,587.99
PERMA	Pass through Payment	652978	12/22/2011	\$2,539.90
<u>CALIFORNIA STATE DISBURSEMENT</u>	Employee Garnishment	652939	12/22/2011	\$2,445.97
<u>CALIFORNIA STATE DISBURSEMENT</u>	Employee Garnishment	652725	12/9/2011	\$2,445.97

**SunLine Transit Agency**  
**Checks \$1,000 and Over**  
**For the month of December 2011**

NOTE: 1). Bold check payments represent "pass through" payments that were, or will be reimbursed to SunLine under the provisions of specific grants or contracts. 2). Underlined check payments represent "shared" payments with SunLine and specific vendors/employees.

<b>Vendor Name</b>	<b>Description</b>	<b>Check #</b>	<b>Check</b>	<b>Amount</b>
FACTORY MOTOR PARTS COMPANY	Repair Parts	652757	12/9/2011	\$2,275.64
<u>CALIFORNIA STATE DISBURSEMENT</u>	<u>Employee Garnishment</u>	<u>652671</u>	<u>12/1/2011</u>	<u>\$2,272.89</u>
<u>EYE MED</u>	<u>Employee Benefits</u>	<u>652754</u>	<u>12/9/2011</u>	<u>\$2,185.44</u>
NEW FLYER	Bus Parts	652797	12/9/2011	\$2,048.03
FLEET-NET CORPORATION	Software & Licenses	652762	12/9/2011	\$2,040.00
BURRTEC WASTE & RECYCLING	Facility Trash Removal	652934	12/22/2011	\$1,939.66
TRANSIT PRODUCTS & SERVICES	Repair Parts	652832	12/9/2011	\$1,851.80
<u>SHERIFF'S COURT SERVICES - EAST</u>	<u>Employee Garnishment</u>	<u>652818</u>	<u>12/9/2011</u>	<u>\$1,842.02</u>
ALLIEDBARTON SECURITY SERVICES	Security Services	652929	12/22/2011	\$1,660.96
<u>SHERIFF'S COURT SERVICES - EAST</u>	<u>Employee Garnishment</u>	<u>652984</u>	<u>12/22/2011</u>	<u>\$1,648.02</u>
OFFICE DEPOT	Office Supplies	652800	12/9/2011	\$1,609.46
FIESTA FORD, INC.	Repair Parts/Support	652954	12/22/2011	\$1,592.43
ALLIEDBARTON SECURITY SERVICES	Security Services	652709	12/9/2011	\$1,542.32
CALSTART, INC.	Membership Fee	652940	12/22/2011	\$1,500.00
<u>SHERIFF'S COURT SERVICES - EAST</u>	<u>Employee Garnishment</u>	<u>652688</u>	<u>12/1/2011</u>	<u>\$1,473.57</u>
<b><i>CLASSIC PARTY RENTALS</i></b>	<b><i>WIP-AFCB Project</i></b>	<b><i>652738</i></b>	<b><i>12/9/2011</i></b>	<b><i>\$1,372.18</i></b>
VERIZON	Communications	652841	12/9/2011	\$1,365.34
SWRCB ACCOUNTING OFFICE	Annual Storm Water Fee	652831	12/9/2011	\$1,359.00
CREATIVE BUS SALES, INC.	Bus Repair Parts	652742	12/9/2011	\$1,355.08
<b><i>PRINTING PLACE, THE</i></b>	<b><i>WIP-AFCB Project</i></b>	<b><i>652806</i></b>	<b><i>12/9/2011</i></b>	<b><i>\$1,333.95</i></b>
MARY BORDERS	Holiday Gala Raffle Gifts	652695	12/5/2011	\$1,300.00
SUN CHEMICAL	Bus & Facility Cleaner	652826	12/9/2011	\$1,284.68
VERIZON WIRELESS	Wireless Cell Serv	652842	12/9/2011	\$1,282.23
SMART CHEMISTRY CORPORATION	Hydrogen Samples	652820	12/9/2011	\$1,250.00
ABBA PHOTOGRAPHY	Employee Event	652701	12/9/2011	\$1,200.00
OFFICETEAM	Temporary Services	652974	12/22/2011	\$1,132.47
OFFICETEAM	Temporary Services	652801	12/9/2011	\$1,127.40
ACCONTEMPS	Temporary Help	00652667	12/1/2011	\$1,116.00
ACCONTEMPS	Temporary Help	00652705	12/9/2011	\$1,116.00
CUMMINS CAL PACIFIC, LLC	Bus Repair Parts	00652743	12/9/2011	\$1,114.25
VIP PROMOTIONAL SERVICES	Advertising	00652844	12/9/2011	\$1,061.76
APPLEBEE'S	Holiday Gift Cert	00652716	12/9/2011	\$1,000.00

<b>Total of Checks Over \$1,000</b>	<b>\$735,134.00</b>
<b>Total of Checks Under \$1,000</b>	<b>\$54,770.16</b>
<b>Total of All Checks for the Month</b>	<b>\$789,904.16</b>

**Total Amount of Checks Prior Years Same Month** \$2,310,500.01 <sup>10</sup>



**November Statement** for activity from Oct. 21, 2011 through Nov. 21, 2011  
 SUNLINE TRANSIT  
 C MIKEL OGLESBY (CPN 000648533)

**Inquiries: 1-866-552-8855**  
 BUS 7 13 Page 1 of 2

**Your Visa® Business Card account at a glance ... Account: 4798 5100 4480 9131**

Activity Summary	
Previous Balance .....	\$3,615.70
Payments .....	\$3,615.70CR
Other Credits .....	\$0.00
Purchases .....	\$1,478.45
Balance Transfers .....	\$0.00
Advances .....	\$0.00
Other Debits .....	\$0.00
Past Due Amount .....	\$0.00
Fees Charged .....	\$0.00
Interest Charged .....	\$0.00
<b>New Balance .....</b>	<b>\$1,478.45</b>
Credit Line .....	\$34,000.00
Available Credit .....	\$32,521.55
Statement Close Date .....	Nov. 21, 2011
Days in Billing Cycle .....	32

Payment Information	
New Balance .....	\$1,478.45
Minimum Payment Due (Current Month)	\$15.00
Minimum Payment Due (Past Due)	\$0.00
<b>Total New Minimum Payment Due</b>	<b>\$15.00</b>
Payment Due Date .....	Dec. 17, 2011
<b>Late Payment Warning:</b> If we do not receive your minimum payment by the date listed above, you may have to pay up to a \$39.00 Late Fee and your APRs may be increased up to the Penalty APR of 28.99%.	

To reduce or avoid paying additional fees and interest charges on your purchase balance, pay the total new balance of \$1,478.45 by 12/17/11. Any cash balance or balance transfer balance will continue to accrue daily interest until the date your payment is received.

**Transactions**

Post Date	Trans Date	Ref. Nbr	Description of Transaction	Amount	Notation
<b>Payments and Other Credits</b>					
11/04			PAYMENT THANK YOU.....	\$3,615.70CR	-----
<b>Purchases and Other Debits</b>					
10/24	10/21	4162	CONFERENCE/EVENT REGIS 916-3692880 CA .....	\$275.00	-----
11/07	11/05	4101	MARRIOTT 337Z4 SAN JOS SAN JOSE CA..... 10/31/11 FOR 05 NIGHTS FOLIO: 1610020400003	\$869.96	-----
11/07	11/05	1651	MARRIOTT 337Z4 SAN JOS SAN JOSE CA.....	\$33.49	-----

Continued on Next Page

No payment is required, however please use coupon when making additional payments. CPN 000648533

0047985100448091310000015000001478457

**Automatic Payment**

Your Account Number: 4798 5100 4480 9131
Your new full balance of \$1,478.45 will be automatically deducted from your account on 12/05/11.

To change your address or for Cardmember Service please call: 1-866-552-8855 **Every Hour! Every Day!**

000031169 1 MB 0.390 106481346653344 P

SUNLINE TRANSIT  
 C MIKEL OGLESBY  
 32505 HARRY OLIVER TRL  
 THOUSAND PLMS CA 92276-3501





**November Statement** for activity from Oct. 21, 2011 through Nov. 21, 2011  
 SUNLINE TRANSIT  
 C MIKEL OGLESBY (CPN 000648533)

**Inquiries: 1-866-552-8855**  
 Page 2 of 2

**Transactions**

Post Date	Trans Date	Ref. Nbr	Description of Transaction	Amount	Notation
11/21	11/18	0380	TRANSITNEWS.NET 407-2071870 FL.....	\$300.00	-----

2011 Totals Year-to-Date	
Total Fees Charged in 2011	\$0.00
Total Interest Charged in 2011	\$0.00

**Company Approval** *(This area for use by your company)*

Signature/Approval: \_\_\_\_\_ Accounting Code: \_\_\_\_\_

**Interest Charge Calculation**

Your Annual Percentage Rate (APR) is the annual interest rate on your account.

\*\*APR for current and future transactions.

Balance Type	Balance By Type	Balance Subject to Interest Rate	Variable	Interest Charge	Annual Percentage Rate	Expires with Statement	Interest Free Period
**BALANCE TRANSFER	\$0.00	\$0.00	YES	\$0.00	13.99%		NO
**PURCHASES	\$1,478.45	\$0.00	YES	\$0.00	13.99%		YES
**ADVANCES	\$0.00	\$0.00	YES	\$0.00	20.99%		NO

**Important Messages**

Your payment of \$1478.45 will be automatically deducted from your bank account on 12/05/2011

Save time and money by consolidating all your debt into one monthly payment. Check your mail for a great offer or call Cardmember Service today for information on a great rate.

**To contact us regarding your account... 4798 5100 4480 9131**



**By Telephone:**  
*Every Hour! Every Day!*  
 Voice: 1-866-552-8855  
 TDD: 1-888-352-6455  
 Fax: 1-866-807-9053



**Send Inquiries to:**  
 Cardmember Service  
 P.O. Box 6353  
 Fargo, ND 58125-6353



**Send Payments to:**  
 Cardmember Service  
 P.O. Box 790408  
 St. Louis, MO 63179-0408



**Online**  
 visit our website:  
 myaccountaccess.com

Pacific Western Bank  
 SunLine Transit Agency Visa Credit Card Statement  
 Closing Date: November 21, 2011

Detail:			
10/24/11	Conference Event	CTA Conference registration – Operations Manager	\$ 275.00
11/07/11	Marriott – San Jose	CTA Conference – hotel – General Manager	\$ 869.96
11/07/11	Marriott – San Jose	CTA Conference – hotel – General Manager	\$ 33.49
11/21/11	TRANSITNEWS.NET	Subscription – Transit News – one year	\$ 300.00
Credit:			
11/04/11	Payment		\$3615.70CR

Note: All travel is currently funded in the Board approved FY 2012 budget.



December Statement for activity from Nov. 22, 2011 through Dec. 21, 2011  
 SUNLINE TRANSIT  
 C MIKEL OGLESBY (CPN 000648533)

Inquiries: 1-866-552-8855  
 BUS 7 13 Page 1 of 2

Your Visa® Business Card account at a glance ... Account: 4798 5100 4480 9131

Activity Summary	
Previous Balance .....	\$1,478.45
Payments .....	\$1,478.45CR
Other Credits .....	\$0.00
Purchases .....	\$695.00
Balance Transfers .....	\$0.00
Advances .....	\$0.00
Other Debits .....	\$0.00
Past Due Amount .....	\$0.00
Fees Charged .....	\$0.00
Interest Charged .....	\$0.00
<b>New Balance .....</b>	<b>\$695.00</b>
Credit Line .....	\$34,000.00
Available Credit .....	\$33,305.00
Statement Close Date .....	Dec. 21, 2011
Days in Billing Cycle .....	30

Payment Information	
New Balance .....	\$695.00
Minimum Payment Due (Current Month)	\$10.00
Minimum Payment Due (Past Due)	\$0.00
<b>Total New Minimum Payment Due</b>	<b>\$10.00</b>
Payment Due Date .....	Jan. 17, 2012
<p><b>Late Payment Warning:</b> If we do not receive your minimum payment by the date listed above, you may have to pay up to a \$39.00 Late Fee and your APRs may be increased up to the Penalty APR of 28.99%.</p>	

To reduce or avoid paying additional fees and interest charges on your purchase balance, pay the total new balance of \$695.00 by 01/17/12. Any cash balance or balance transfer balance will continue to accrue daily interest until the date your payment is received.

**Transactions**

Post Date	Trans Date	Ref. Nbr	Description of Transaction	Amount	Notation
<b>Payments and Other Credits</b>					
12/05			PAYMENT THANK YOU .....	\$1,478.45CR	-----
<b>Purchases and Other Debits</b>					
12/14	12/13	6784	AMERICAN PUBLIC TRANS 202-4964800 DC .....	\$695.00	-----

Continued on Next Page

No payment is required, however please use coupon when making additional payments. CPN 000648533

0047985100448091310000010000000695007

**Automatic Payment**

Your Account Number: 4798 5100 4480 9131  
 Your new full balance of \$695.00 will be automatically deducted from your account on 01/04/12.

To change your address or for Cardmember Service please call: 1-866-552-8855 *Every Hour! Every Day!*

000031279 1 MB 0.390 106481392095147 P

SUNLINE TRANSIT  
 C MIKEL OGLESBY  
 32505 HARRY OLIVER TRL  
 THOUSAND PLMS CA 92276-3501





**December Statement** for activity from Nov. 22, 2011 through Dec. 21, 2011  
 SUNLINE TRANSIT  
 C MIKEL OGLESBY (CPN 000648533)

**Inquiries: 1-866-552-8855**  
 Page 2 of 2

2011 Totals Year-to-Date	
Total Fees Charged in 2011	\$0.00
Total Interest Charged in 2011	\$0.00

**Company Approval** *(This area for use by your company)*

Signature/Approval: \_\_\_\_\_ Accounting Code: \_\_\_\_\_

**Interest Charge Calculation**

Your Annual Percentage Rate (APR) is the annual interest rate on your account.

\*\*APR for current and future transactions.

Balance Type	Balance By Type	Balance Subject to Interest Rate	Variable	Interest Charge	Annual Percentage Rate	Expires with Statement	Interest Free Period
**BALANCE TRANSFER	\$0.00	\$0.00	YES	\$0.00	13.99%		NO
**PURCHASES	\$695.00	\$0.00	YES	\$0.00	13.99%		YES
**ADVANCES	\$0.00	\$0.00	YES	\$0.00	20.99%		NO

**Important Messages**

Your payment of \$695.00 will be automatically deducted from your bank account on 01/04/2012

Save time and money by consolidating all your debt into one monthly payment. Check your mail for a great offer or call Cardmember Service today for information on a great rate.

**To contact us regarding your account... 4798 5100 4480 9131**

 **By Telephone:**  
*Every Hour! Every Day!*  
 Voice: 1-866-552-8855  
 TDD: 1-888-352-6455  
 Fax: 1-866-807-9053

 **Send Inquiries to:**  
 Cardmember Service  
 P.O. Box 6353  
 Fargo, ND 58125-6353

 **Send Payments to:**  
 Cardmember Service  
 P.O. Box 790408  
 St. Louis, MO 63179-0408

 **Online**  
 visit our website:  
[myaccountaccess.com](http://myaccountaccess.com)

Pacific Western Bank  
SunLine Transit Agency Visa Credit Card Statement  
Closing Date: December 21, 2011

Detail:

12/14/11 AMERICAN PUBLIC TRANS APTA CEO Conf. Registration – General Manager \$ 695.00

Credit:

12/05/11 Payment \$1478.45CR

Note: All travel is currently funded in the Board approved FY 2012 budget.

**SunLine Transit Agency  
Statement of Activities  
November 2011**

	Unaudited FY 10/11	Total FY 11/12 Budget	Current Month		Year to Date			
			Actual	Budget	YTD Actual	YTD Budget	Favorable (Unfavorable)	
<b>Operating Revenue:</b>								
Passenger Fares	2,893,849	2,950,000	254,638	245,833	8,805	1,278,547	1,229,167	49,381
Advertising Revenue	27,024	25,000	0	2,083	(2,083)	16,983	10,417	6,567
Rebate for CNG Production	1,035,857	375,000	59,805	62,500	(2,695)	330,392	312,500	17,892
Interest Revenue	8,573	10,000	183	833	(651)	1,339	4,167	(2,827)
Outside Fueling Revenue (SunFuels)	219,868	180,137	20,795	14,382	6,413	129,142	73,648	55,495
Pass-Through Operating revenue	69,777	258,800	16,246	21,567	(5,321)	32,371	107,833	(75,462)
Other Operating Revenue	107,833	343,137	11,409	28,595	(17,186)	42,463	142,974	(100,511)
Grant Revenue	17,004,918	19,225,376	1,261,330	1,261,330	0	7,887,601	7,887,601	0
<b>Total Revenue</b>	<b>21,367,700</b>	<b>23,367,450</b>	<b>1,624,405</b>	<b>1,637,123</b>	<b>(12,718)</b>	<b>9,718,839</b>	<b>9,768,306</b>	<b>(49,467)</b>
<b>Expenses:</b>								
SunFuels (10)	219,868	180,137	22,571	14,382	(8,188)	130,994	73,648	(57,346)
Operations-Fixed Route (11 & 12)	8,453,305	8,670,062	697,612	703,178	5,566	3,535,088	3,598,489	63,401
Operations-Dial-A-Ride (13 & 14)	2,232,339	2,450,562	203,050	198,399	(4,651)	980,160	999,202	19,042
Security (15)	514,549	458,833	36,378	36,283	(95)	187,215	186,582	(633)
Maintenance (21 & 22)	5,212,682	5,517,967	425,231	449,566	24,335	2,204,373	2,279,230	74,857
Facility Maintenance-T.P. (23)	567,807	573,218	48,300	47,514	(786)	251,940	237,073	(14,867)
Facility Maintenance-Indio (24)	81,905	83,472	4,693	6,956	2,263	30,937	34,780	3,843
Bus Stops/Shelters (25)	416,057	459,965	36,053	36,879	825	172,294	188,192	15,897
Marketing (31)	261,442	356,354	23,714	28,901	5,187	113,500	146,744	33,244
Human Resources (32)	451,763	407,998	29,459	33,021	3,563	128,687	167,560	38,873
General Administration (40)	1,032,497	1,483,415	111,978	121,312	9,335	585,243	614,794	29,551
Finance (41)	755,754	753,377	70,365	59,435	(10,931)	294,937	288,967	(5,969)
Information Technology (42)	289,135	367,125	22,159	30,344	8,185	120,539	152,674	32,136
Planning & Agency Development (49)	599,879	851,833	39,671	71,594	31,924	178,016	328,580	150,564
<b>Total expenses</b>	<b>21,088,982</b>	<b>22,614,318</b>	<b>1,771,233</b>	<b>1,837,764</b>	<b>66,531</b>	<b>8,913,922</b>	<b>9,296,514</b>	<b>382,592</b>

Minimum Farebox ratio = 17.80%

YTD Farebox ratio

20.54%

**Preliminary Statement Prior To Audit Field Work**

# SunLine Transit Agency

## Statement of Revenues and Departmental Expenditures For Month ended November 30, 2011

<b>Operating Revenue</b>	<b>11/30/11</b>	<b>YTD</b>
Passenger Fares	254,638	1,278,547
Advertising Revenue	-	16,983
Rebate for CNG Production	59,805	330,392
Interest Revenue	183	1,339
Outside Fueling Revenue (SunFuels)	20,795	129,142
Pass-Through Operating Revenue	16,246	32,371
Other Operating Revenue	11,409	42,463
<b>Total Operating Revenue</b>	<b>\$ 363,075</b>	<b>\$ 1,831,238</b>
 <b>Grant Revenue</b>		
Local Transportation Funds (LTF)	777,166	5,096,041
Measure A Funds	354,740	1,773,700
FTA Section 5307 <sup>1</sup>	125,000	585,094
FTA Section 5304	-	4,077
FTA Section 5311	-	-
FTA Section 5316	-	7,362
FTA Section 5317	-	3,851
CMAQ	-	-
Other Grant Revenue <sup>2</sup>	4,424	417,476
<b>Total Grant Revenue</b>	<b>\$ 1,261,330</b>	<b>\$ 7,887,601</b>
 <b>TOTAL REVENUE</b>	 <b>\$ 1,624,405</b>	 <b>\$ 9,718,839</b>
 <b>Operating Expenditures by Department</b>		
SunFuels (10)	22,571	130,994
Operations-Fixed Route (11 & 12)	697,612	3,535,088
Operations-Dial-A-Ride (13 & 14)	203,050	980,160
Security (15)	36,378	187,215
Maintenance (21 & 22)	425,231	2,204,373
Facility Maintenance-T.P. (23)	48,300	251,940
Facility Maintenance-Indio (24)	4,693	30,937
Bus Stops/Shelters (25)	36,053	172,294
Marketing (31)	23,714	113,500
Human Resources (32)	29,459	128,687
General Administration (40)	111,978	585,243
Finance (41)	70,365	294,937
Information Technology (42)	22,159	120,539
Planning & Agency Development (49)	39,671	178,016
<b>TOTAL OPERATING EXPENDITURES</b>	<b>\$ 1,771,233</b>	<b>\$ 8,913,922</b>
 <b>OPERATING INCOME/(LOSS)</b>	 <b>(146,828)</b>	 <b>804,917</b>

<sup>1</sup> Includes \$125,000 accrual of Preventative Maintenance funds totalling \$1,250,000 annually

<sup>2</sup> Includes \$360,380 for 2009 Funds Receivable

Contracts Signed Under General Manager Authorization

January 2012

Vendor	Product/Service	Need	GM Authorization	Cost
Advance Web Offset Printing	Bus Schedule Booklets	Printing Services	Part of Board approved FY2011/2012 Budget	\$38,000.00

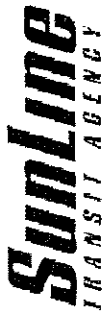

SunLine Transit Agency  
 Monthly Ridership Report  
 November - 2011

FY  
 2011 & 2012

Fixed Route	Nov 2011	Nov 2010	Oct 2011	Month		FY 2012	FY 2011	YTD	%	%	Bikes		Wheelchairs	
				Var.	YTD						YTD	YTD	YTD	YTD
Line 14 DHS/PS	44,430	39,569	47,911	4,861	12.3%	212,092	201,151	10,941	5.4%	1,045	6,244	453	2,264	
Line 15 DHS	8,280	6,258	9,169	2,022	32.3%	38,392	18,862	19,530	103.5%	148	682	61	588	
Line 24 PS/CC	16,763	14,706	19,322	2,057	14.0%	77,742	67,183	10,559	15.7%	273	1,394	101	648	
Line 30 CC/PS	67,242	62,688	72,520	4,554	7.3%	318,249	289,348	28,901	10.0%	1,748	9,379	589	2,478	
Line 32 PD/TP/PS	21,193	17,997	22,319	3,196	17.8%	97,050	77,368	19,682	25.4%	696	3,899	101	459	
Line 53 PD/IW	4,601	3,996	4,853	605	15.1%	19,609	11,347	8,262	72.8%	118	482	21	62	
Line 70 La Quinta	22,924	19,162	24,898	3,762	19.6%	96,910	82,428	14,482	17.6%	747	3,921	16	62	
Line 80 Indio	20,259	19,246	21,919	1,013	5.3%	97,333	91,806	5,527	6.0%	230	1,412	255	1,038	
Line 90 Coachella/Ind	19,049	16,903	21,060	2,146	12.7%	91,231	81,866	9,365	11.4%	421	2,462	180	769	
Line 91 Cch/Th/Mecca	20,143	15,173	21,352	4,970	32.8%	91,607	68,034	23,573	34.6%	369	2,001	45	222	
Line 111 PS/Indio	136,716	124,433	142,431	12,283	9.9%	648,413	581,488	66,925	11.5%	4,599	22,671	901	4,446	
<b>Fixed route total</b>	<b>381,600</b>	<b>340,131</b>	<b>407,754</b>	<b>41,469</b>	<b>12.2%</b>	<b>1,788,628</b>	<b>1,581,447</b>	<b>207,181</b>	<b>13.1%</b>	<b>10,394</b>	<b>54,547</b>	<b>2,723</b>	<b>13,036</b>	

**Demand Response**

SunDial	10,051	8,658	10,667	1,393	16.1%	50,266	45,349	4,917	10.8%
<b>System total</b>	<b>391,651</b>	<b>348,789</b>	<b>418,421</b>	<b>42,862</b>	<b>12.3%</b>	<b>1,838,894</b>	<b>1,626,796</b>	<b>212,098</b>	<b>13.0%</b>

**Please note:**

\* FY 2011 YTD total ridership includes data for Line 50 (10,566 passengers). Line 50 was discontinued on September 4, 2010; fixed route and system totals are accurate.

SunLine Transit Agency  
 Monthly Ridership Report  
 November - 2011

Fixed Route Ridership

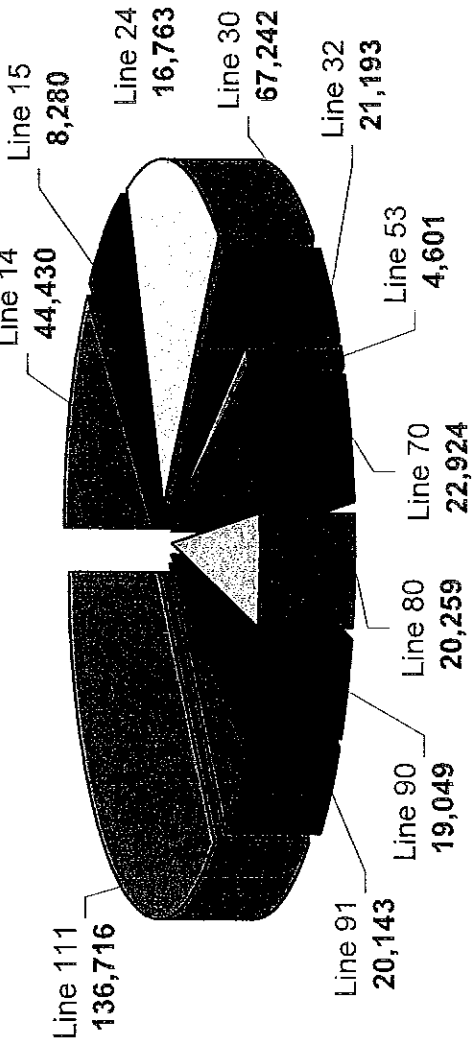

Demand Response Ridership

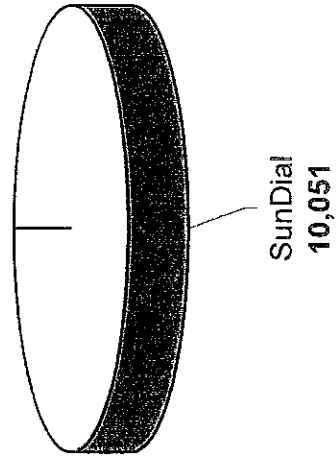

Year-to-Date System Ridership

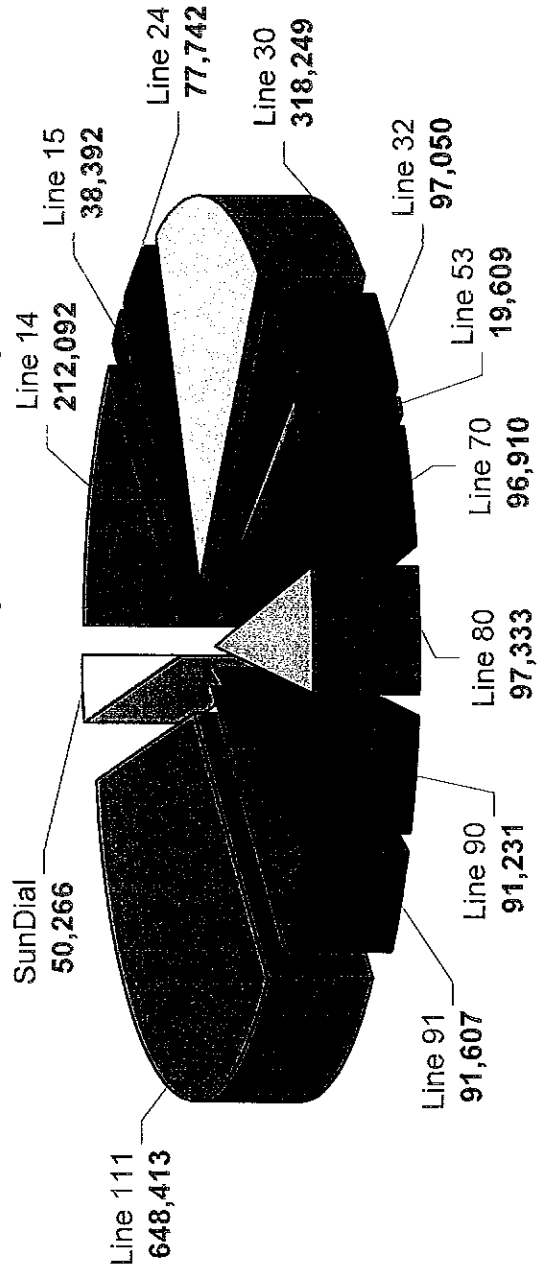

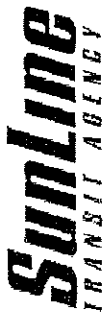

**SunLine Transit Agency  
Monthly Ridership Report  
December - 2011**

FY  
2011 & 2012

	Dec	Dec	Nov	Month	%	FY 2012	FY 2011	YTD	%	Bikes		Wheelchairs	
	2011	2010	2011	Var.	Var.	YTD	YTD	Var.	Var.	Monthly	YTD	Monthly	YTD
<b>Fixed Route</b>													
Line 14 DHS/PS	42,160	36,914	44,430	5,246	14.2%	254,252	238,065	16,187	6.8%	979	7,223	390	2,654
Line 15 DHS	7,550	6,568	8,280	982	15.0%	45,942	25,430	20,512	80.7%	70	752	38	626
Line 24 PS/CC	15,228	12,922	16,763	2,306	17.8%	92,970	80,105	12,865	16.1%	292	1,686	139	787
Line 30 CC/PS	63,763	57,880	67,242	5,883	10.2%	382,012	347,228	34,784	10.0%	1,629	11,008	591	3,069
Line 32 PD/TP/PS	19,380	17,438	21,193	1,942	11.1%	116,430	94,806	21,624	22.8%	630	4,529	82	541
Line 53 PD/IW	4,095	3,744	4,601	351	9.4%	23,704	15,091	8,613	57.1%	133	615	21	83
Line 70 La Quinta	19,527	17,375	22,924	2,152	12.4%	116,437	99,803	16,634	16.7%	684	4,605	14	76
Line 80 Indio	17,419	17,912	20,259	(493)	-2.8%	114,752	109,718	5,034	4.6%	235	1,647	181	1,219
Line 90 Coachella/Ind	18,872	16,995	19,049	1,877	11.0%	110,103	98,861	11,242	11.4%	323	2,785	173	942
Line 91 Cch/Th/Mecca	18,610	14,607	20,143	4,003	27.4%	110,217	82,641	27,576	33.4%	333	2,334	52	274
Line 111 PS/Indio	134,206	122,676	136,716	11,530	9.4%	782,619	704,164	78,455	11.1%	4,086	26,757	1,015	5,461
<b>Fixed route total</b>	<b>360,810</b>	<b>325,031</b>	<b>381,600</b>	<b>35,779</b>	<b>11.0%</b>	<b>2,149,438</b>	<b>1,906,478</b>	<b>242,960</b>	<b>12.7%</b>	<b>9,394</b>	<b>63,941</b>	<b>2,696</b>	<b>15,732</b>
<b>Demand Response</b>													
SunDial	9,610	8,687	10,051	923	10.6%	59,876	54,036	5,840	10.8%				
<b>System total</b>	<b>370,420</b>	<b>333,718</b>	<b>391,651</b>	<b>36,702</b>	<b>11.0%</b>	<b>2,209,314</b>	<b>1,960,514</b>	<b>248,800</b>	<b>12.7%</b>				

**Please note:**

\* FY 2011 YTD total ridership includes data for Line 50 (10,566 passengers). Line 50 was discontinued on September 4, 2010; fixed route and system totals are accurate.

Issued: 1/9/2012

# SunLine Transit Agency Monthly Ridership Report December - 2011

## Fixed Route Ridership

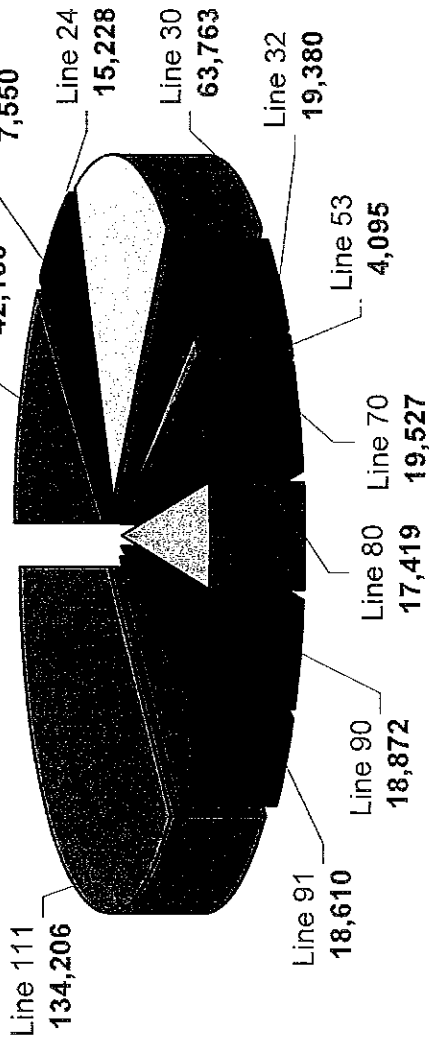

## Demand Response Ridership

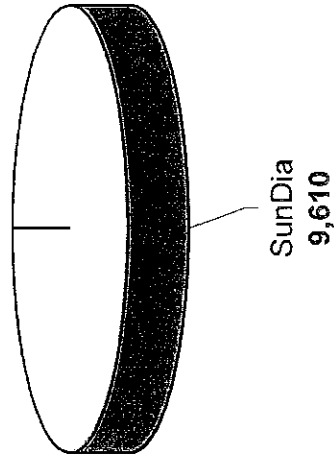

## Year-to-Date System Ridership

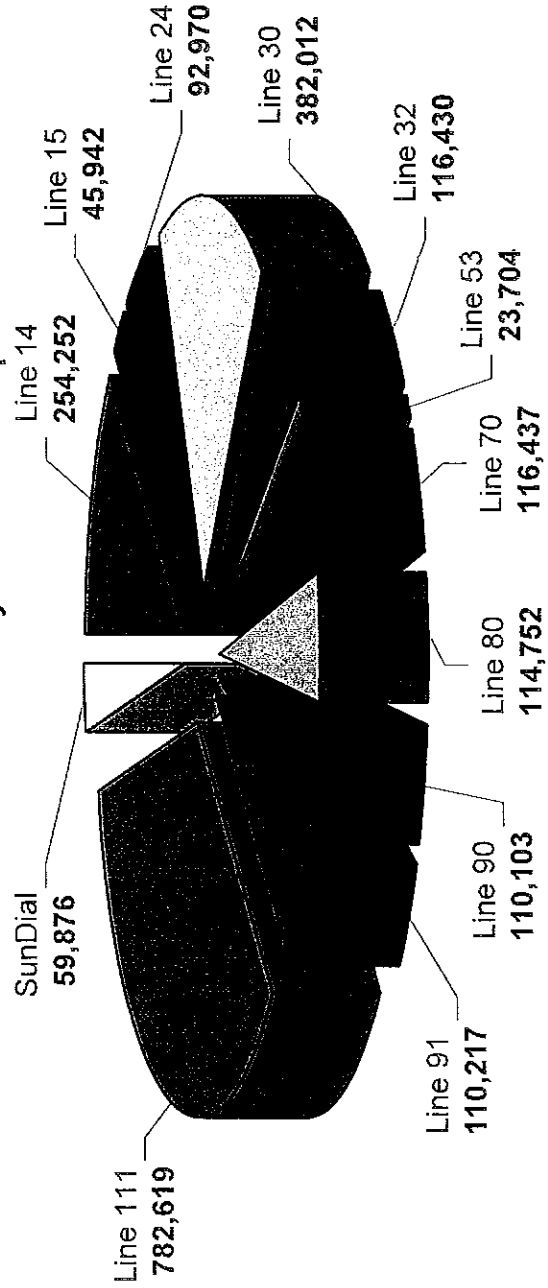



**SunDial Operational Notes**  
**November 2011**

1. ON-TIME PERFORMANCE

<u>Last Year</u>	<u>This Year</u>	
92.5%	88.7%	Total trips carried in the on-time window
637	1,177	Total trips late during the month
8,014	9,870	Total trips

2. RIDERSHIP and MILEAGE

<u>Last Year</u>	<u>This Year</u>	
8,658	10,051	Total passengers for the month
67,397	85,346	Total miles traveled for the month

3. SAFETY

<u>Last Year</u>	<u>This Year</u>	
0	0	Total preventable accidents

4. RIDE-A-LONG & ONBOARD EVALUATIONS

<u>Last Year</u>	<u>This Year</u>	
1	0	Total ride-a-long evaluations
1	7	Total onboard inspections
2	3	Total safety evaluations

5. DENIALS

<u>Last Year</u>	<u>This Year</u>	
0	0	Total denied trips

6. WHEELCHAIR BOARDINGS

<u>Last Year</u>	<u>This Year</u>	
1,329	1,606	Total mobility device boarding's

cc: Mikel Oglesby, Carolyn Rude, Polo Del Toro, Mannie Thomas, Jim Rayl, Diane Beebe



**SunDial Operational Notes  
December 2011**

1. ON-TIME PERFORMANCE

<u>Last Year</u>	<u>This Year</u>	
90.9%	90.4%	Total trips carried in the on-time window
777	898	Total trips late during the month
8,015	9,439	Total trips

2. RIDERSHIP and MILEAGE

<u>Last Year</u>	<u>This Year</u>	
8,687	9,610	Total passengers for the month
71,016	84,524	Total miles traveled for the month

3. SAFETY

<u>Last Year</u>	<u>This Year</u>	
0	0	Total preventable accidents

4. RIDE-A-LONG & ONBOARD EVALUATIONS

<u>Last Year</u>	<u>This Year</u>	
0	1	Total ride-a-long evaluations
2	11	Total onboard inspections
2	1	Total safety evaluations

5. DENIALS

<u>Last Year</u>	<u>This Year</u>	
0	0	Total denied trips

6. WHEELCHAIR BOARDINGS

<u>Last Year</u>	<u>This Year</u>	
1,224	1,456	Total mobility device boarding's

cc: Mikel Oglesby, Carolyn Rude, Polo Del Toro, Mannie Thomas, Jim Rayl, Diane Beebe

**SunLine Transit Agency**

**DATE:** January 25, 2012 **ACTION**  
**TO:** Finance Committee  
Board of Directors  
**FROM:** General Manager  
**RE:** General Counsel

---

**Recommendation**

Recommend that the Board of Directors: a) accept Legal Counsel's request to be relieved from the remainder of their contract with SunLine Transit Agency/SunLine Services Group; **and** b) approve appointment of interim Legal Counsel.

**Background**

General Counsel appointment by the Board of Directors is provided in the SunLine Transit Agency Joint Powers Agreement. SunLine staff relies on Counsel to support the ongoing operations of the Agency. On December 9, 2011, SunLine received a letter from its General Counsel requesting that they be released from the remainder of the contract period. The contract for General Counsel was executed on November 9, 2009.

The terms of the contract are for one year with four additional 1-year options.

The Board of Directors evaluates General Counsel and provides direction to staff on an annual basis.

Mr. Robert W. Hargreaves of Best, Best & Krieger LLP was sought as interim counsel but was not available. He instead referred staff to Rutan & Tucker, LLP as being familiar with the types of issues currently being considered by the Board.

**Financial Impact**

Staff has included funds for General Counsel in its operating budget. Rutan's charges exceed the hourly rate being paid for current legal support.

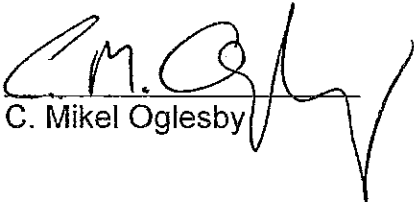
  
C. Mikel Oglesby